

### Integrally Heated Sprue Bushings

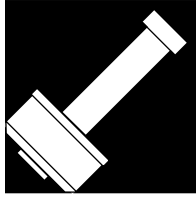

The Integrally Heated Sprue Bushing is an exclusive medium to large volume bushing with the ability to process a wide range of resins. The streamlined flow channel terminates in a reverse taper gate, providing minimum pressure loss and allowing for rapid gate freeze. The formation of a small gate stub on the part or runner results in a machine hold-time reduction, with no increase in sink marks on the part.

The superior heat transfer ability of the Heated Sprue Bushing can be attributed to its integrally heated design. To optimize processing conditions for all thermoplastics, a replaceable thermocouple is strategically located close to the flow channel.

The Integrally Heated Sprue Bushing is available in three flow diameters, two head styles and three gate styles to suit a broad range of applications.

### Gating Options for Sprue Bushings

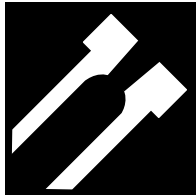

#### Sprue Gate –

Suitable for most applications, the Sprue gate is provided as standard on the Heated Sprue Bushing. **Please note that this style gate is not intended for machining.** The press fit areas are held to +/- .0005" (See engineering charts on pages 5, 9 and 13).

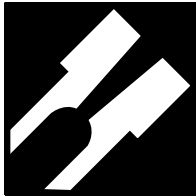

#### Extra Stock Sprue Gate –

The Extra Stock Sprue gate is available for applications requiring machining of the gate area for runner profiles, part contours, or adjustment of the bushing height. The .750" diameter and 1.00" diameter bushings have .500" of extra stock, while the 1.500" diameter bushing has .750" of extra stock. The press fit areas are held to +/- .0005" (See engineering charts on pages 5, 9 and 13).

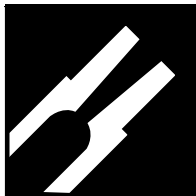

#### Eurostyle Sprue Gate –

Originally designed for the European market, the Eurostyle Sprue Gate is similar to the extra stock gate except that it also has a reduced gate diameter to allow gating in more restricted areas. This design also minimizes heat loss at the press fit area. The press fit areas are held to +/- .0005" (See engineering charts on pages 5, 9 and 13).

### Head Options for Sprue Bushings



#### .500" Radius\* –

Provided with a 0.500" radius to mate in 0.500" radius machine nozzles. Reinforced contact area for improved strength and heat transfer.



#### .750" Radius\* –

Provided with a 0.750" radius to mate in 0.750" radius machine nozzles. Reinforced contact area for improved strength and heat transfer.

**\*Other radiuses are available by special request.**

# Sprue Bushing Technical Specifications

## .750" Series

All specifications are subject to change without notification.

### Head Options

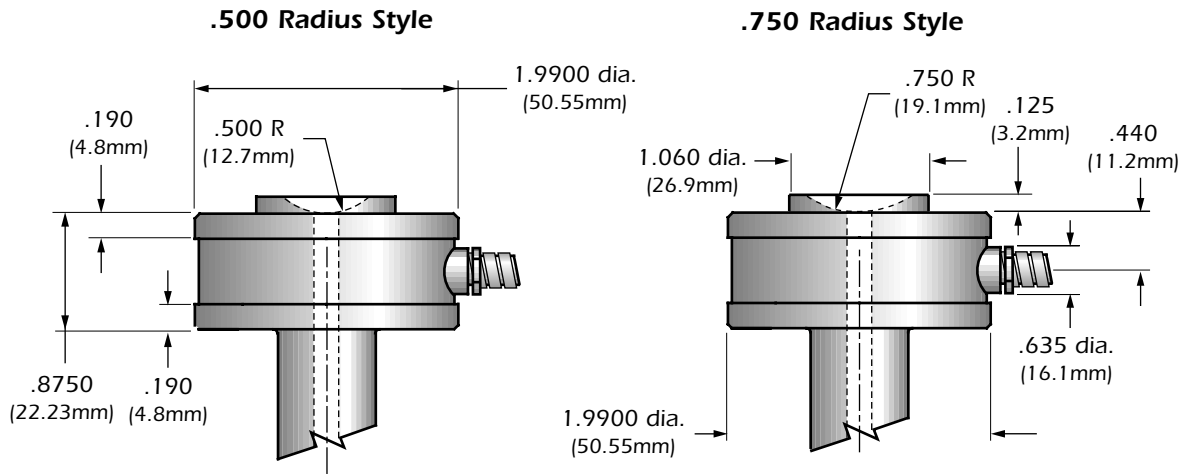

### Gating Options / Bushing Dimensions

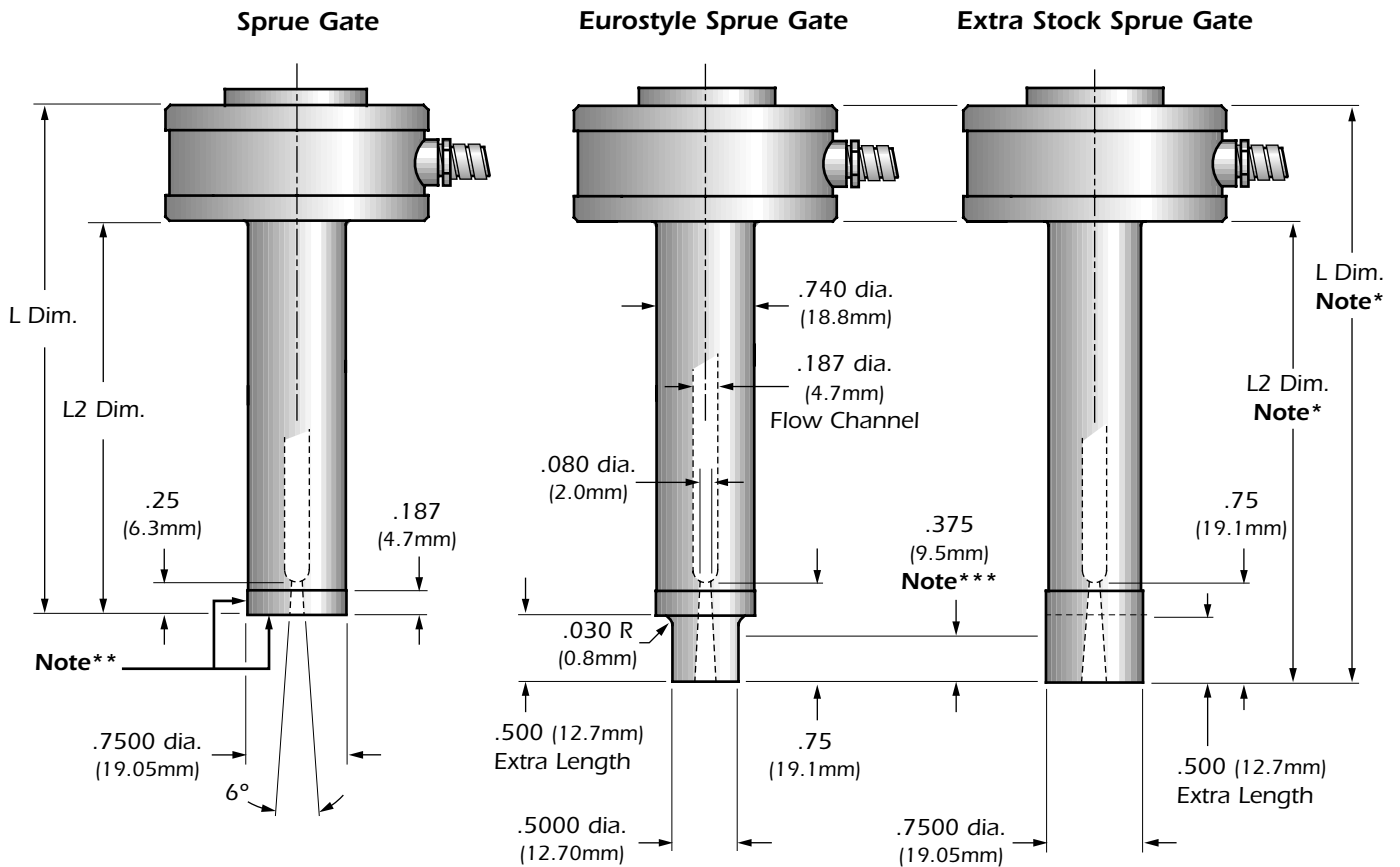

\* Dimensions include extra length.

\*\* This surface cannot be machined, modified or altered.

\*\*\* Maximum machining stock, only this area can be machined.

Dimensions are in inches. Millimeters are in parentheses.  
Note: For additional gate dimensions see page 4.



DIRECT FEED APPLICATIONS

# Sprue Bushing Technical Specifications

## .750" Series Ordering Charts

All specifications are subject to change without notification.

### Chart A

Gate Style	L Dim.		L2 Dim.		.500 Radius Head	.750 Radius Head	Watts	Thermocouple
 Sprue	2.375"	(60.3)	1.500"	(38.1)	SB030000	SB030001	315	MT020020
	2.875"	(73.0)	2.000"	(50.8)	SB030008	SB030009	370	MT020020
	3.375"	(85.7)	2.500"	(63.5)	SB030016	SB030017	425	MT020020
	3.875"	(98.4)	3.000"	(76.2)	SB030024	SB030025	480	MT020020
	4.375"	(111.1)	3.500"	(88.9)	SB030032	SB030033	535	MT020021
 Extra Stock Sprue	2.875"	(73.0)	2.000"	(50.8)	SB030004	SB030005	315	MT020020
	3.375"	(85.7)	2.500"	(63.5)	SB030012	SB030013	370	MT020020
	3.875"	(98.4)	3.000"	(76.2)	SB030020	SB030021	425	MT020020
	4.375"	(111.1)	3.500"	(88.9)	SB030028	SB030029	480	MT020020
	4.875"	(123.8)	4.000"	(101.6)	SB030036	SB030037	535	MT020021
 Eurostyle Sprue	2.875"	(73.0)	2.000"	(50.8)	SB040061	SB040062	315	MT020020
	3.375"	(85.7)	2.500"	(63.5)	SB040065	SB040066	370	MT020020
	3.875"	(98.4)	3.000"	(76.2)	SB040069	SB040070	425	MT020020
	4.375"	(111.1)	3.500"	(88.9)	SB040073	SB040074	480	MT020020
	4.875"	(123.8)	4.000"	(101.6)	SB040077	SB040078	535	MT020021

Dimensions are in inches. Millimeters are in parentheses.

### Lead Exit Options

Lead Exit	Right	Front	Back
Braid	■	■	■
Armor	*	N/A	N/A

\* Standard Lead exit –  
60" (1.52m) teflon wrap - 600 Volt leads;  
right angle lead exit; and 6" (15.2cm)  
stainless steel, square-lock armor cable.

Right (Standard)

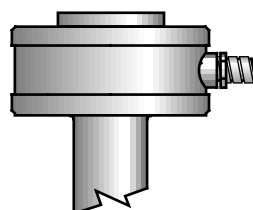

Front

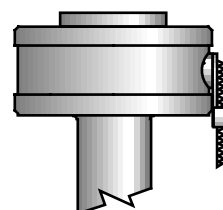

Back

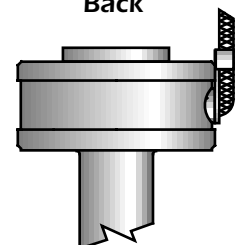

DIRECT-FEED APPLICATIONS



# Sprue Bushing Technical Specifications

## .750" Series Engineering Charts

All specifications are subject to change without notification.

### Chart 1

.750" Series Resin Compatibility Chart			
Gating Options	Commodity Resin	Engineering Resin	Glass-Filled Resin
Sprue	●	●	●
Extra Stock Sprue	●	●	●
Eurostyle Sprue	●	●	●

Reference: ● = Recommended

### Chart 2

.750" Series Gate Diameters			
Gating Options	Resin Viscosity		
	High	Medium	Low
Sprue	.080" to .125"* Max. (2mm to 3.2mm* Max.)	.080" to .125"* Max. (2mm to 3.2mm* Max.)	.080" to .125"* Max. (2mm to 3.2mm* Max.)
Extra Stock Sprue	.080" to .125"* Max. (2mm to 3.2mm* Max.)	.080" to .125"* Max. (2mm to 3.2mm* Max.)	.080" to .125"* Max. (2mm to 3.2mm* Max.)
Eurostyle Sprue	.080" to .125"* Max. (2mm to 3.2mm* Max.)	.080" to .125"* Max. (2mm to 3.2mm* Max.)	.080" to .125"* Max. (2mm to 3.2mm* Max.)

Reference: High Viscosity = Melt Flow (0.02 – 6); Medium Viscosity = Melt Flow (7 – 16); Low Viscosity = Melt Flow (16 – up). The values expressed in grams are for reference purposes only. Part dimensions, wall thickness, mold condition, and molding parameters must also be considered.

\* Re-machine gate diameter, if necessary, for larger shot weights. Maintain gate angle and remove all machine marks.

### Chart 3

.750" Series Maximum Shot Weights in Grams (0.080" Gate)			
Gating Options	Resin Viscosity		
	High	Medium	Low
Sprue	50g	150g	300g
Extra Stock Sprue	50g	150g	300g
Eurostyle Sprue	50g	150g	300g

Consult Tutco Hot Runner Dept. when changing Max. shot weight.

DIRECT FEED APPLICATIONS

# Sprue Bushing Technical Specifications

## 1.000" Series

All specifications are subject to change without notification.

### Head Options

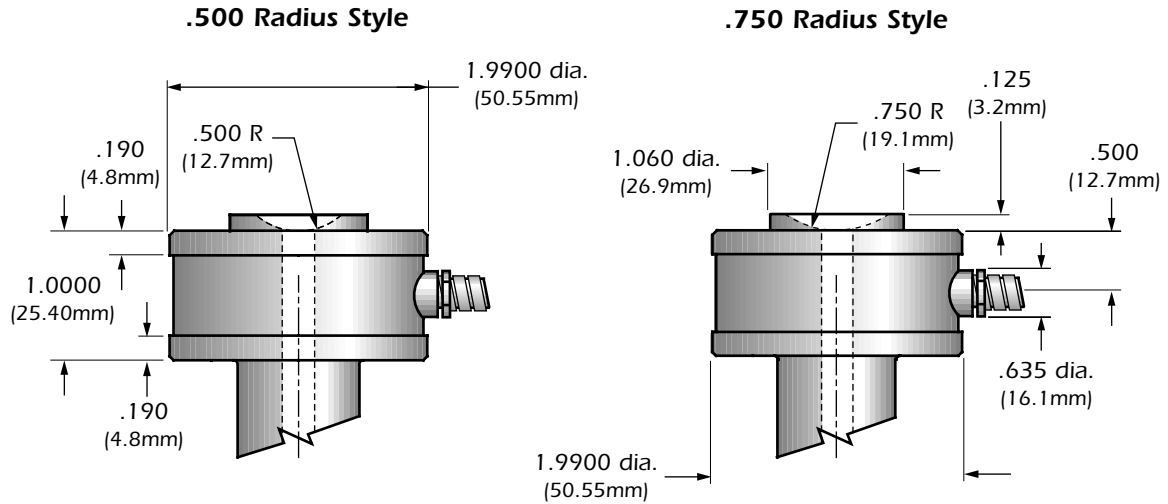

### Gating Options / Bushing Dimensions

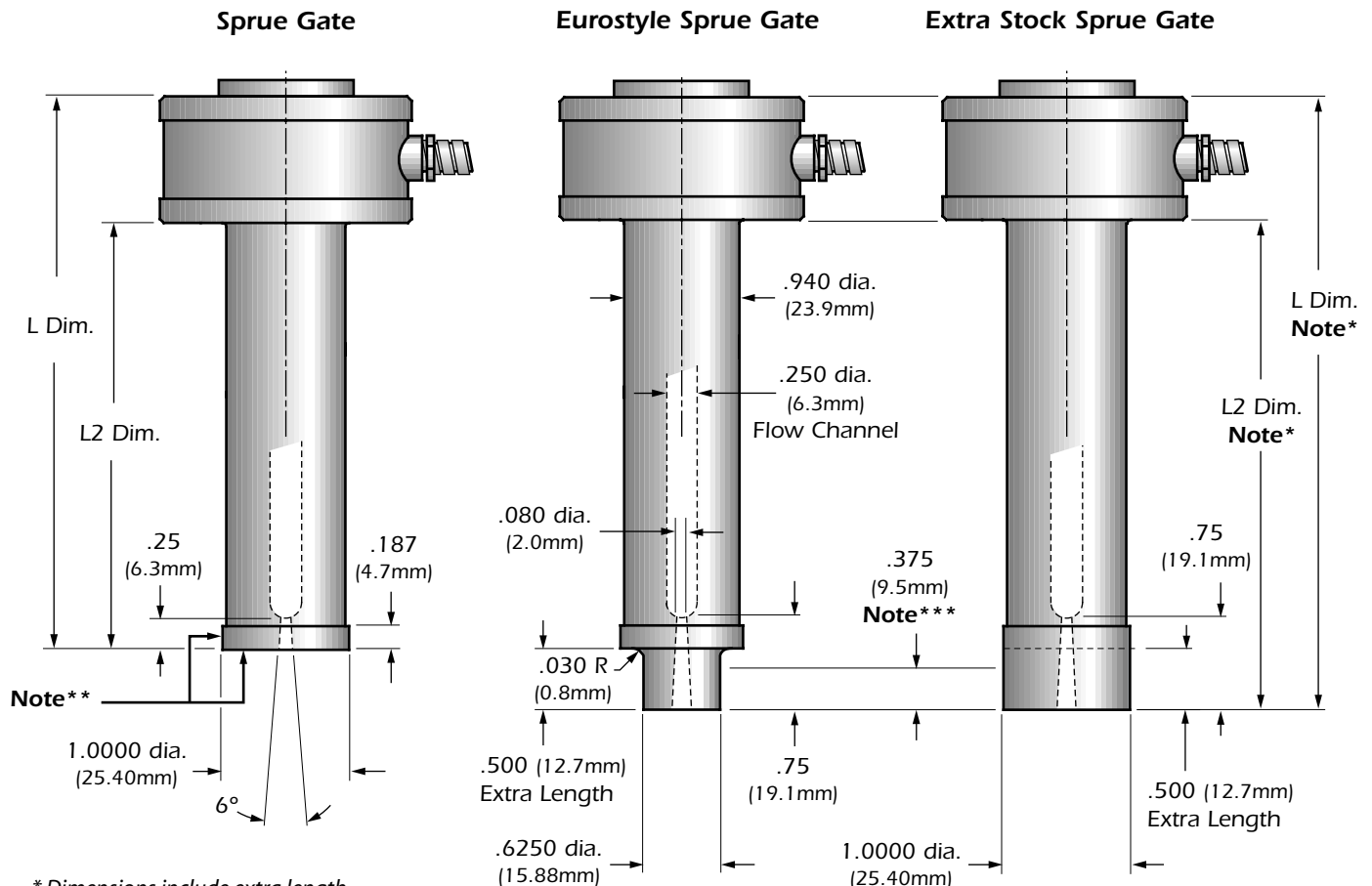

\* Dimensions include extra length.

\*\* This surface cannot be machined, modified or altered.

\*\*\* Maximum machining stock, only this area can be machined.

Dimensions are in inches. Millimeters are in parentheses.  
Note: For additional gate dimensions see page 8.

6



DIRECT FEED APPLICATIONS

# Sprue Bushing Technical Specifications

## 1.000" Series Ordering Charts

All specifications are subject to change without notification.

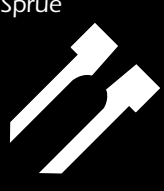
### Chart A

Gate Style	L Dim.		L2 Dim.		.500 Radius Head	.750 Radius Head	Watts	Thermocouple
 Sprue	2.375"	(60.3)	1.375"	(34.9)	SB030040	SB030041	325	MT020020
	2.875"	(73.0)	1.875"	(47.6)	SB030048	SB030049	380	MT020020
	3.375"	(85.7)	2.375"	(60.3)	SB030056	SB030057	435	MT020020
	3.875"	(98.4)	2.875"	(73.0)	SB030064	SB030065	490	MT020020
	4.375"	(111.1)	3.375"	(85.7)	SB030072	SB030073	545	MT020021
	4.875"	(123.8)	3.875"	(98.4)	SB030080	SB030081	600	MT020021
	5.375"	(136.5)	4.375"	(111.1)	SB030088	SB030089	655	MT020021
	5.875"	(149.2)	4.875"	(123.8)	SB030096	SB030097	710	MT020021
	6.375"	(161.9)	5.375"	(136.5)	SB030104	SB030105	765	MT020022
	6.875"	(174.6)	5.875"	(149.2)	SB030112	SB030113	820	MT020022
7.375"	(187.3)	6.375"	(161.9)	SB030120	SB030121	875	MT020022	
 Extra Stock Sprue	2.875"	(73.0)	1.875"	(47.6)	SB030044	SB030045	325	MT020020
	3.375"	(85.7)	2.375"	(60.3)	SB030052	SB030053	380	MT020020
	3.875"	(98.4)	2.875"	(73.0)	SB030060	SB030061	435	MT020020
	4.375"	(111.1)	3.375"	(85.7)	SB030068	SB030069	490	MT020020
	4.875"	(123.8)	3.875"	(98.4)	SB030076	SB030077	545	MT020021
	5.375"	(136.5)	4.375"	(111.1)	SB030084	SB030085	600	MT020021
	5.875"	(149.2)	4.875"	(123.8)	SB030092	SB030093	655	MT020021
	6.375"	(161.9)	5.375"	(136.5)	SB030100	SB030101	710	MT020021
	6.875"	(174.6)	5.875"	(149.2)	SB030108	SB030109	765	MT020022
	7.375"	(187.3)	6.375"	(161.9)	SB030116	SB030117	820	MT020022
7.875"	(200.0)	6.875"	(174.6)	SB030124	SB030125	875	MT020022	
 Eurostyle Sprue	2.875"	(73.0)	1.875"	(47.6)	SB040081	SB040082	325	MT020020
	3.375"	(85.7)	2.375"	(60.3)	SB040085	SB040086	380	MT020020
	3.875"	(98.4)	2.875"	(73.0)	SB040089	SB040090	435	MT020020
	4.375"	(111.1)	3.375"	(85.7)	SB040093	SB040094	490	MT020020
	4.875"	(123.8)	3.875"	(98.4)	SB040097	SB040098	545	MT020021
	5.375"	(136.5)	4.375"	(111.1)	SB040101	SB040102	600	MT020021
	5.875"	(149.2)	4.875"	(123.8)	SB040105	SB040106	655	MT020021
	6.375"	(161.9)	5.375"	(136.5)	SB040109	SB040110	710	MT020021
	6.875"	(174.6)	5.875"	(149.2)	SB040113	SB040114	765	MT020022
	7.375"	(187.3)	6.375"	(161.9)	SB040117	SB040118	820	MT020022
7.875"	(200.0)	6.875"	(174.6)	SB040121	SB040122	875	MT020022	

Dimensions are in inches. Millimeters are in parentheses.

### Lead Exit Options

Lead Exit	Right	Front	Back
Braid	▪	▪	▪
Armor	*	N/A	N/A

\* Standard Lead exit –  
60" (1.52m) teflon wrap - 600 Volt leads;  
right angle lead exit; and 6" (15.2cm)  
stainless steel, square-lock armor cable.

Right (Standard)

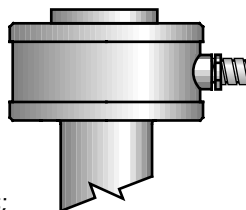

Front

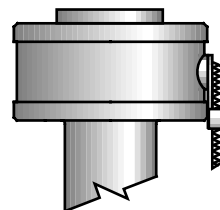

Back

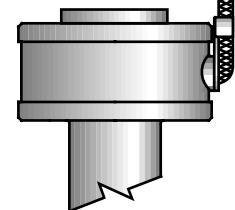

DIRECT FEED APPLICATIONS

# Sprue Bushing Technical Specifications

## 1.000" Series Bore & Gate Dimensions

All specifications are subject to change without notification.

### Insulating Washer Ordering

	Top	Bottom
Part#	MAX10015	MAX10015
O.D.	1.99 (50.5mm)	1.99 (50.5mm)
I.D.	1.07 (27.2mm)	1.07 (27.2mm)
Thickness	.125 (3.2mm)	.125 (3.2mm)

Note: Insulating Washers are not required, but are recommended for high temperature applications.

L2 Dim. - .125 + Exp.  
L2 Dim. - (3.2mm) + Exp.  
(See Chart A, page 7 for L2 Dim.)

### Insulating Washer Option

### Standard Bore

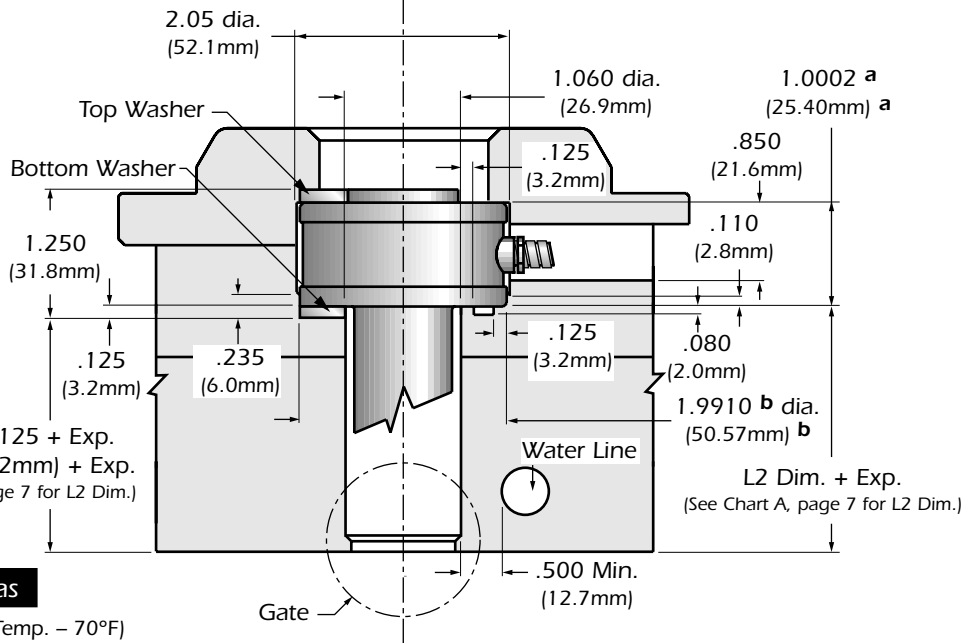

### Thermal Expansion (Exp.) Formulas

Exp. in = L2 in. x 6.88 x 10<sup>-6</sup> x (Processing Temp. - 70°F)

Exp. mm = L2 mm x 13 x 10<sup>-6</sup> x (Processing Temp. - 21°C)

Ref: 10<sup>-6</sup> = 0.000001

### Sprue Gate

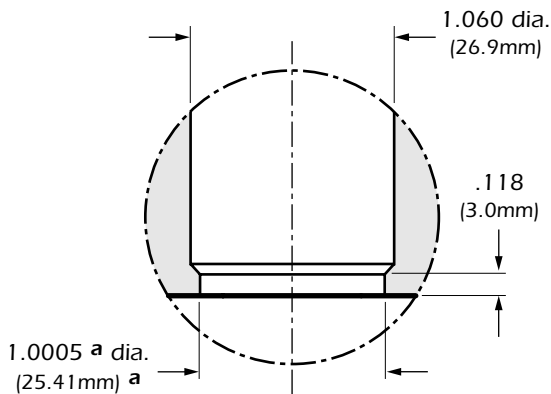

### Extra Stock Sprue Gate

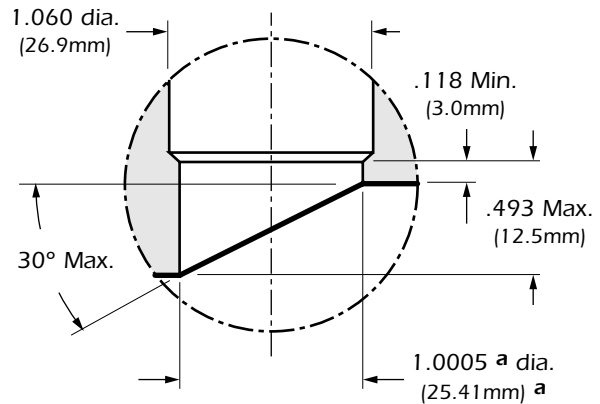

### Eurostyle Sprue Gate

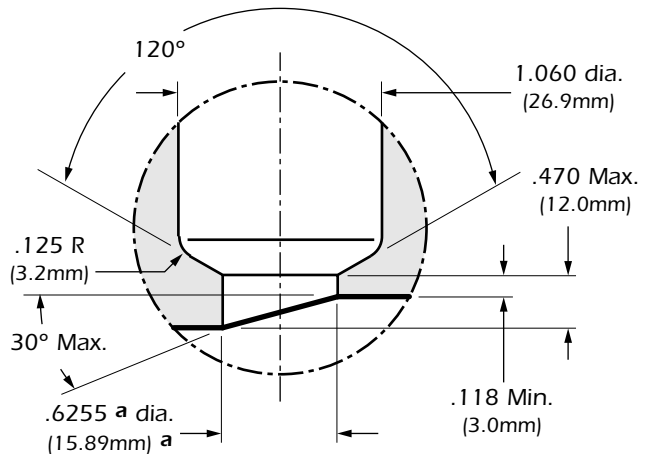

### Bore & Gate Tolerances

Tol. "a" Chart

in: +0.0005  
-0  
mm: +0.01  
-0

Tol. "b" Chart

in: +0.0010  
-0  
mm: +0.02  
-0

8

Dimensions are in inches. Millimeters are in parentheses.

DIRECT FEED APPLICATIONS



# Sprue Bushing Technical Specifications

## 1.000" Series Engineering Charts

All specifications are subject to change without notification.

### Chart 1

#### 1.000" Series Resin Compatibility Chart

Gating Options	Commodity Resin	Engineering Resin	Glass-Filled Resin
Sprue	●	●	●
Extra Stock Sprue	●	●	●
Eurostyle Sprue	●	●	●

Reference: ● = Recommended

### Chart 2

#### 1.000" Series Gate Diameters

Gating Options	Resin Viscosity		
	High	Medium	Low
Sprue	.080" to .156"* Max. (2mm to 4mm* Max.)	.080" to .156"* Max. (2mm to 4mm* Max.)	.080" to .156"* Max. (2mm to 4mm* Max.)
Extra Stock Sprue	.080" to .156"* Max. (2mm to 4mm* Max.)	.080" to .156"* Max. (2mm to 4mm* Max.)	.080" to .156"* Max. (2mm to 4mm* Max.)
Eurostyle Sprue	.080" to .156"* Max. (2mm to 4mm* Max.)	.080" to .156"* Max. (2mm to 4mm* Max.)	.080" to .156"* Max. (2mm to 4mm* Max.)

Reference: High Viscosity = Melt Flow (0.02 – 6); Medium Viscosity = Melt Flow (7 – 16); Low Viscosity = Melt Flow (16 – up). The values expressed in grams are for reference purposes only. Part dimensions, wall thickness, mold condition, and molding parameters must also be considered.

\* Re-machine gate diameter, if necessary, for larger shot weights. Maintain gate angle and remove all machine marks.

### Chart 3

#### 1.000" Series Maximum Shot Weights in Grams (0.080" Gate)

Gating Options	Resin Viscosity		
	High	Medium	Low
Sprue	200g	300g	500g
Extra Stock Sprue	200g	300g	500g
Eurostyle Sprue	200g	300g	500g

Consult Tutco Hot Runner Dept. when changing Max. shot weight.

DIRECT FEED APPLICATIONS

# Sprue Bushing Technical Specifications

## 1.500" Series

All specifications are subject to change without notification.

### Head Options

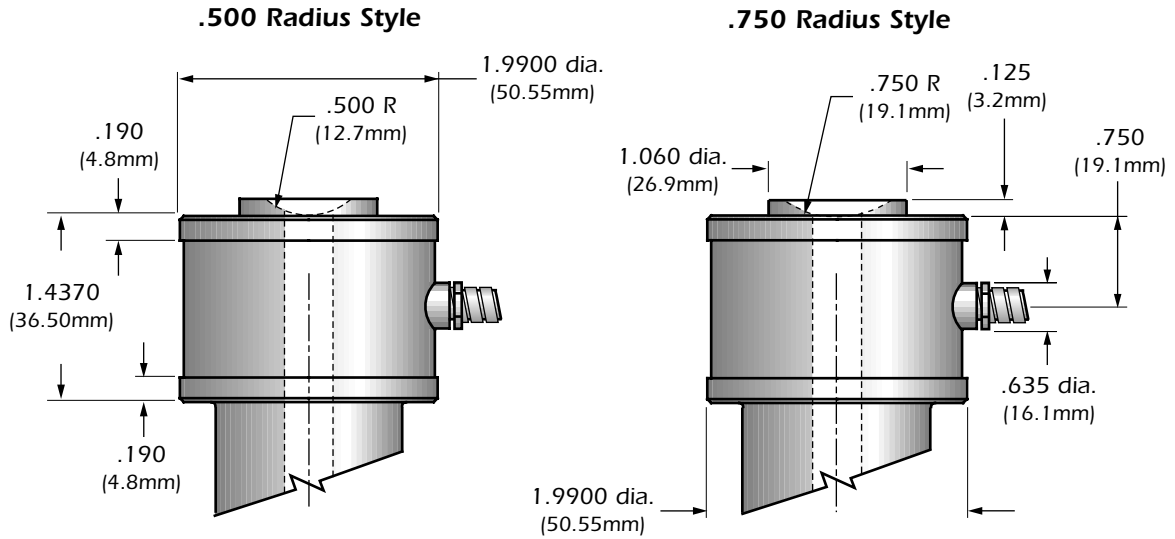

### Gating Options / Bushing Dimensions

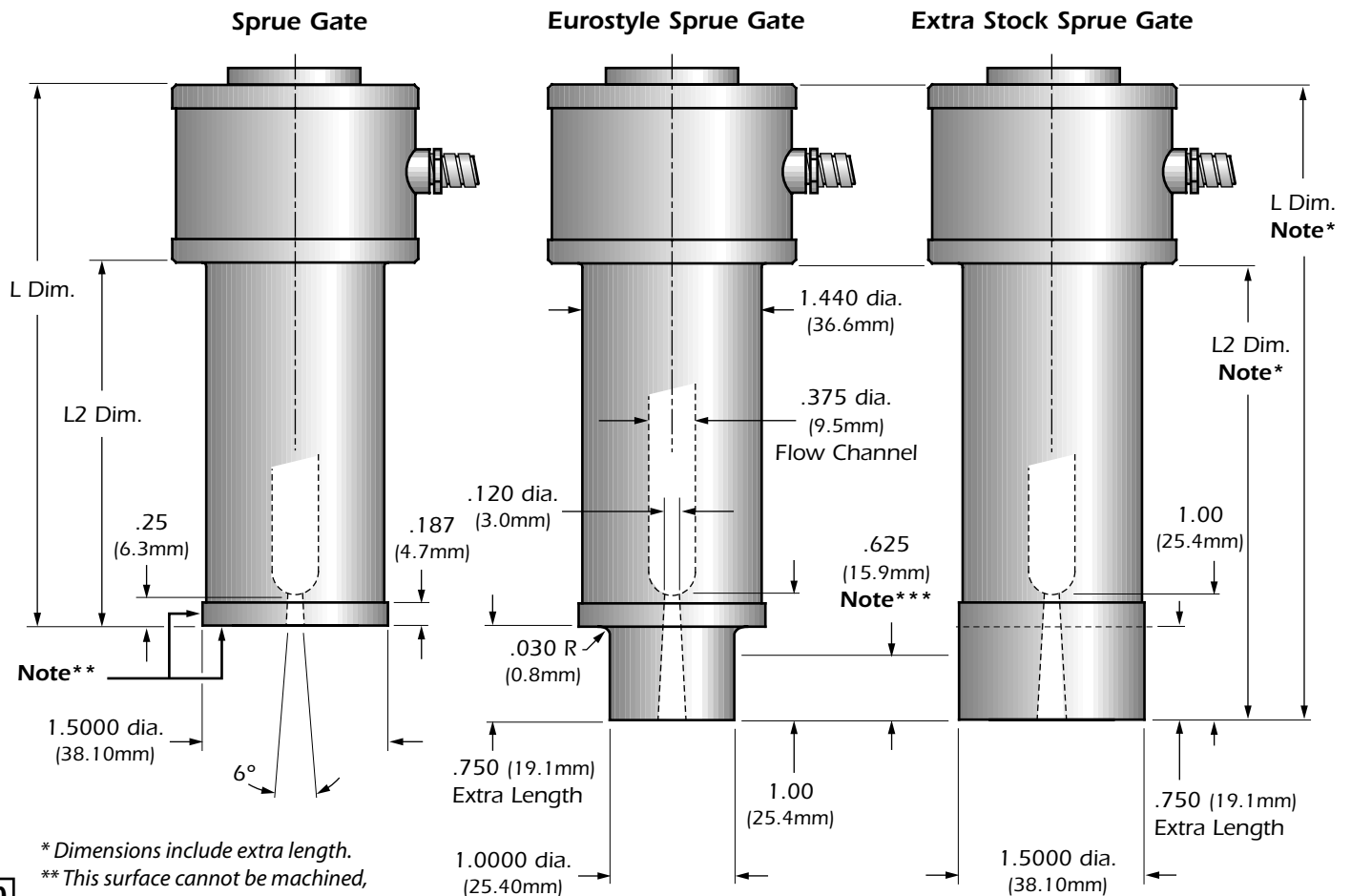

10



DIRECT FEED APPLICATIONS

# Sprue Bushing Technical Specifications

## 1.500" Series Ordering Charts

All specifications are subject to change without notification.

### Chart A

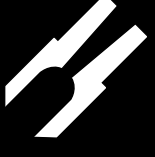
Gate Style	L Dim.		L2 Dim.		.500 Radius Head	.750 Radius Head	Watts	Thermocouple
 Sprue	3.375"	(85.7)	1.938"	(49.2)	SB030128	SB030129	700	MT020020
	3.875"	(98.4)	2.438"	(61.9)	SB030136	SB030137	780	MT020020
	4.375"	(111.1)	2.938"	(74.6)	SB030144	SB030145	860	MT020021
	4.875"	(123.8)	3.438"	(87.3)	SB030152	SB030153	945	MT020021
	5.375"	(136.5)	3.938"	(100.0)	SB030160	SB030161	1025	MT020021
	5.875"	(149.2)	4.438"	(112.7)	SB030168	SB030169	1110	MT020021
	6.375"	(161.9)	4.938"	(125.4)	SB030175	SB030177	1190	MT020022
	6.875"	(174.6)	5.438"	(138.1)	SB030184	SB030185	1275	MT020022
	7.375"	(187.3)	5.938"	(150.8)	SB030192	SB030193	1360	MT020022
Gate Style	L Dim.		L2 Dim.		.500 Radius Head	.750 Radius Head	Watts	Thermocouple
 Extra Stock Sprue	4.125"	(104.8)	2.688"	(68.3)	SB030132	SB030133	700	MT020020
	4.625"	(117.5)	3.188"	(81.0)	SB030140	SB030141	780	MT020020
	5.125"	(130.2)	3.688"	(93.7)	SB030148	SB030149	860	MT020021
	5.625"	(142.9)	4.188"	(106.4)	SB030156	SB030157	945	MT020021
	6.125"	(155.6)	4.688"	(119.1)	SB030164	SB030165	1025	MT020021
	6.625"	(168.3)	5.188"	(131.8)	SB030172	SB030173	1110	MT020021
	7.125"	(181.0)	5.688"	(144.5)	SB030180	SB030181	1190	MT020022
	7.625"	(193.7)	6.188"	(157.2)	SB030188	SB030189	1275	MT020022
	8.125"	(206.4)	6.688"	(169.9)	SB030196	SB030197	1360	MT020022
Gate Style	L Dim.		L2 Dim.		.500 Radius Head	.750 Radius Head	Watts	Thermocouple
 Eurostyle Sprue	4.125"	(104.8)	2.688"	(68.3)	SB040125	SB040126	700	MT020020
	4.625"	(117.5)	3.188"	(81.0)	SB040129	SB040130	780	MT020020
	5.125"	(130.2)	3.688"	(93.7)	SB040133	SB040134	860	MT020021
	5.625"	(142.9)	4.188"	(106.4)	SB040137	SB040138	945	MT020021
	6.125"	(155.6)	4.688"	(119.1)	SB040141	SB040142	1025	MT020021
	6.625"	(168.3)	5.188"	(131.8)	SB040145	SB040146	1110	MT020021
	7.125"	(181.0)	5.688"	(144.5)	SB040149	SB040150	1190	MT020022
	7.625"	(193.7)	6.188"	(157.2)	SB040153	SB040154	1275	MT020022
	8.125"	(206.4)	6.688"	(169.9)	SB040157	SB040158	1360	MT020022

Dimensions are in inches. Millimeters are in parentheses.

### Lead Exit Options

Lead Exit	Right	Front	Back
Braid	▪	▪	▪
Armor	*	N/A	N/A

\* Standard Lead exit –  
60" (1.52m) teflon wrap - 600 Volt leads;  
right angle lead exit; and 6" (15.2cm)  
stainless steel, square-lock armor cable.

Right (Standard)

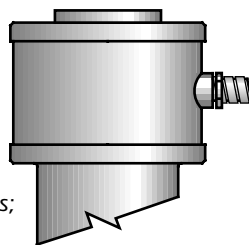

Front

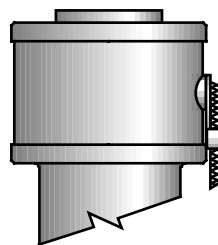

Back

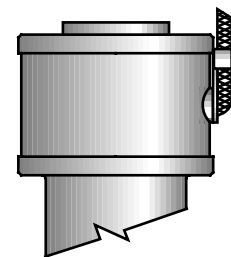

DIRECT FEED APPLICATIONS

# Sprue Bushing Technical Specifications

## 1.500" Series Bore & Gate Dimensions

All specifications are subject to change without notification.

### Insulating Washer Ordering

	Top	Bottom
Part#	MAX10015	MA010036
O.D.	1.99 (50.5mm)	1.99 (50.5mm)
I.D.	1.07 (27.2mm)	1.56 (39.6mm)
Thickness	.125 (3.2mm)	.125 (3.2mm)

Note: Insulating Washers are not required, but are recommended for high temperature applications.

L2 Dim. - .125 + Exp.  
L2 Dim. - (3.2mm) + Exp.  
(See Chart A, page 11 for L2 Dim.)

### Insulating Washer Option

### Standard Bore

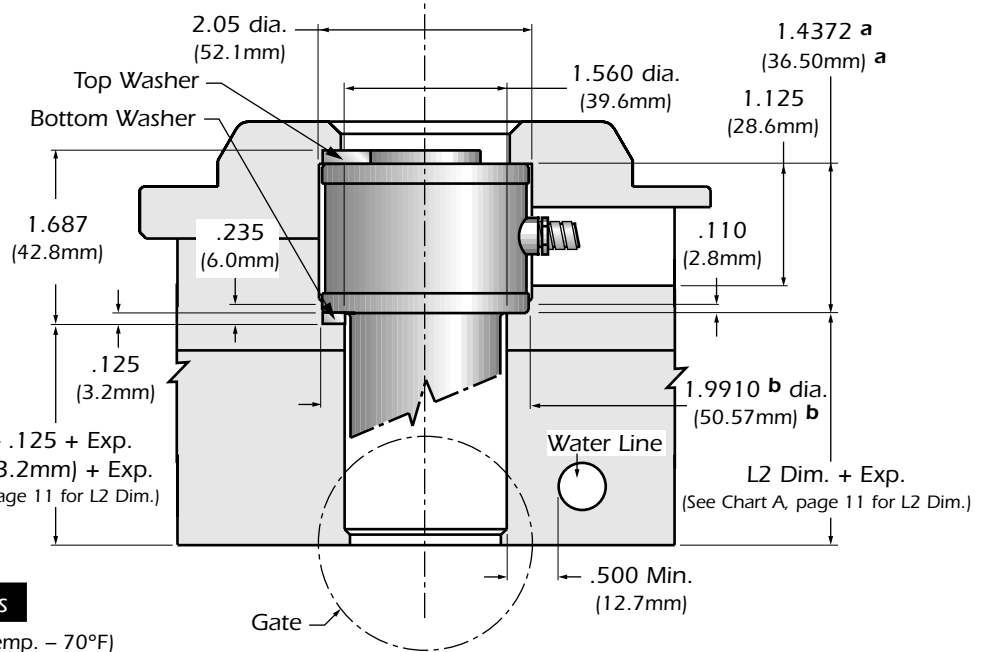

### Thermal Expansion (Exp.) Formulas

Exp. in = L2 in. x 6.88 x 10<sup>-6</sup> x (Processing Temp. - 70°F)

Exp. mm = L2 mm x 13 x 10<sup>-6</sup> x (Processing Temp. - 21°C)

Ref: 10<sup>-6</sup> = 0.000001

### Sprue Gate

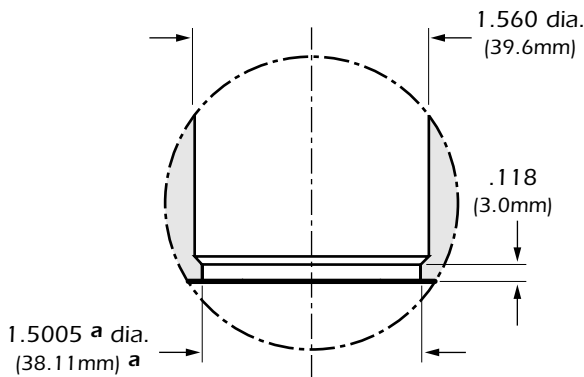

### Extra Stock Sprue Gate

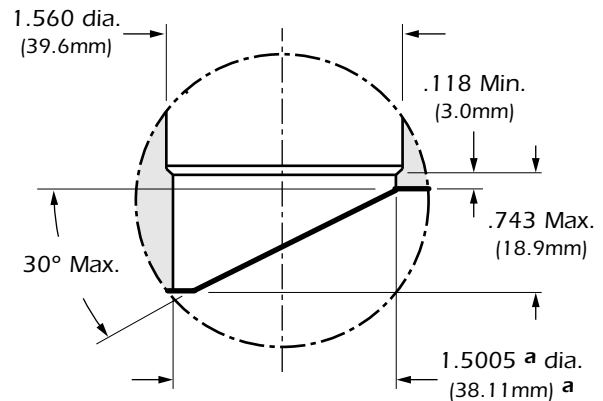

### Eurostyle Sprue Gate

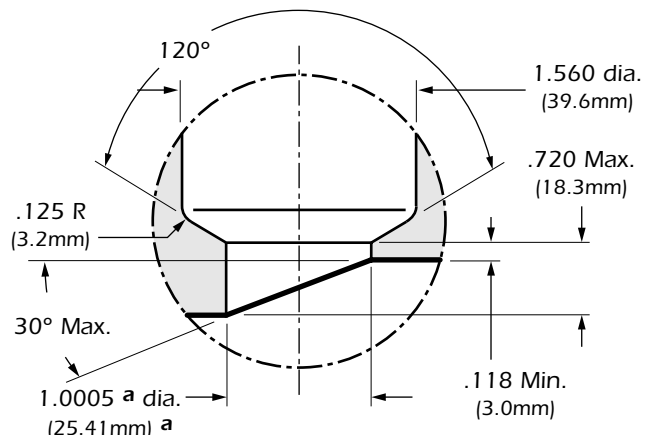

### Bore & Gate Tolerances

Tol. "a" Chart	
in.	$\frac{+0.0005}{-0}$
mm.	$\frac{+0.01}{-0}$

Tol. "b" Chart	
in.	$\frac{+0.0010}{-0}$
mm.	$\frac{+0.02}{-0}$

12

Dimensions are in inches. Millimeters are in parentheses.

DIRECT FEED APPLICATIONS

# Sprue Bushing Technical Specifications

## 1.500" Series Engineering Charts

All specifications are subject to change without notification.

### Chart 1

1.500" Series Resin Compatibility Chart			
Gating Options	Commodity Resin	Engineering Resin	Glass-Filled Resin
Sprue	●	●	●
Extra Stock Sprue	●	●	●
Eurostyle Sprue	●	●	●

Reference: ● = Recommended

### Chart 2

1.500" Series Gate Diameters			
Gating Options	Resin Viscosity		
	High	Medium	Low
Sprue	.120" to .312"* Max. (3mm to 8mm* Max.)	.120" to .312"* Max. (3mm to 8mm* Max.)	.120" to .312"* Max. (3mm to 8mm* Max.)
Extra Stock Sprue	.120" to .312"* Max. (3mm to 8mm* Max.)	.120" to .312"* Max. (3mm to 8mm* Max.)	.120" to .312"* Max. (3mm to 8mm* Max.)
Eurostyle Sprue	.120" to .312"* Max. (3mm to 8mm* Max.)	.120" to .312"* Max. (3mm to 8mm* Max.)	.120" to .312"* Max. (3mm to 8mm* Max.)

Reference: High Viscosity = Melt Flow (0.02 – 6); Medium Viscosity = Melt Flow (7 – 16); Low Viscosity = Melt Flow (16 – up). The values expressed in grams are for reference purposes only. Part dimensions, wall thickness, mold condition, and molding parameters must also be considered.

\* Re-machine gate diameter, if necessary, for larger shot weights. Maintain gate angle and remove all machine marks.

### Chart 3

1.500" Series Maximum Shot Weights in Grams (0.120" Gate)			
Gating Options	Resin Viscosity		
	High	Medium	Low
Sprue	900g	1500g	2500g
Extra Stock Sprue	900g	1500g	2500g
Eurostyle Sprue	900g	1500g	2500g

Consult Tutco Hot Runner Dept. when changing Max. shot weight.

DIRECT FEED APPLICATIONS

# Sprue Bushing Technical Specifications

## Operating/Service Instructions

All specifications are subject to change without notification.

### Operating & Servicing Instructions

The Sprue Bushing bodies are identical in design, but differ in length, diameter and head style. All Sprue Bushings feature: an integrated heater; Type "J" thermocouple; 60" teflon wrap - 600 Volt leads; right angle lead exit; and 6" stainless steel, square-lock armor cable.

### Start-up/Operating Procedures

If the temperature controller does not utilize "soft start" technology, set the controller to 200°F (93.3°C) in automatic or 10% in manual. Allow bushing to "soak" for 15 minutes before increasing to processing temperature. This step will allow the unit to dissipate any moisture and prolong heater life.

### Power Requirements

- 240 Volts AC – 15 amp fuse
- Grounding – Tutco bushings utilize the direct contact of the bushing, mold plates, and machine platens to establish a path for grounding.

**\*WARNING\***

There must be a ground  present between the Mold "Hot Half" and the temperature control system or damage may occur to the bushing, thermocouple and/or temperature control system.

### Locating Ring Dimensions/Chart

L.R.D.	Part Number
3.990" (101.3mm)	ML010012
4.990" (126.7mm)	ML010025

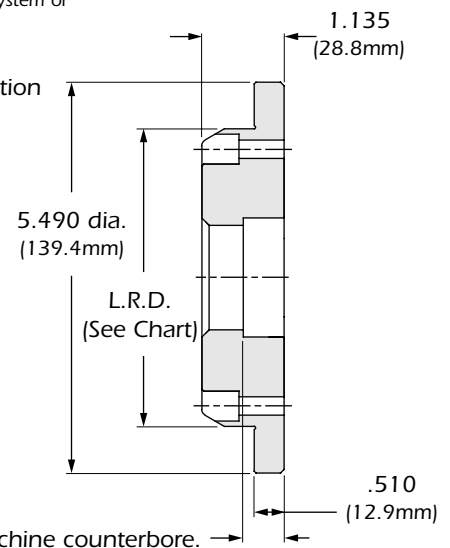
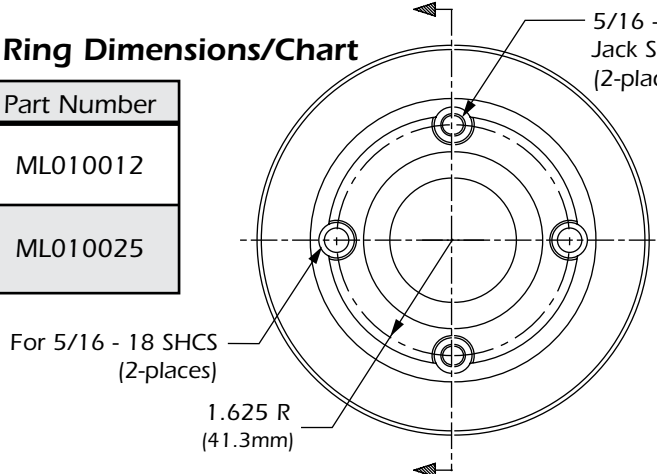

### Machining Options for Keying

#### .750" & 1.000" Series

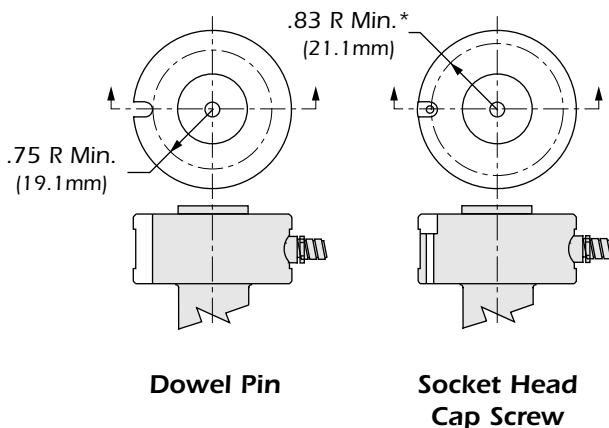

#### 1.500" Series

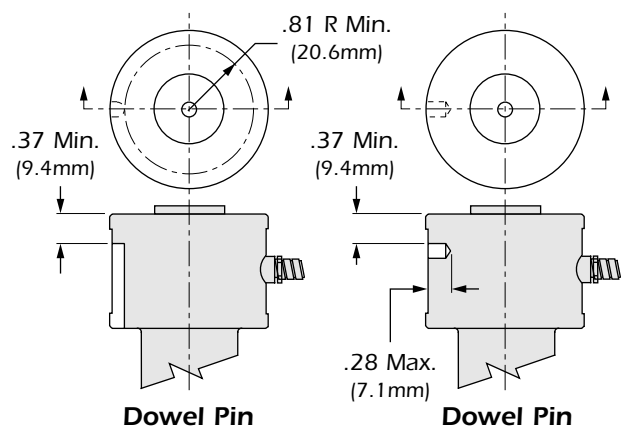

\*Centerline for No. 10 screw.

Dimensions are in inches. Millimeters are in parentheses.